



JOHN DEERE

PowerTech™ 4045D Diesel Engine Specifications

PERFORMANCE DATA

Rated Power

Intermittent 80 hp (60 kW) @ 2500 rpm
Continuous 72 hp (54 kW) @ 2500 rpm

Peak Torque

Intermittent 218 lb-ft (296 N.m) @ 1400 rpm

Fuel Economy

BSFC 0.417 lb/hp-hr (254 g/kWh) @ 2500 rpm

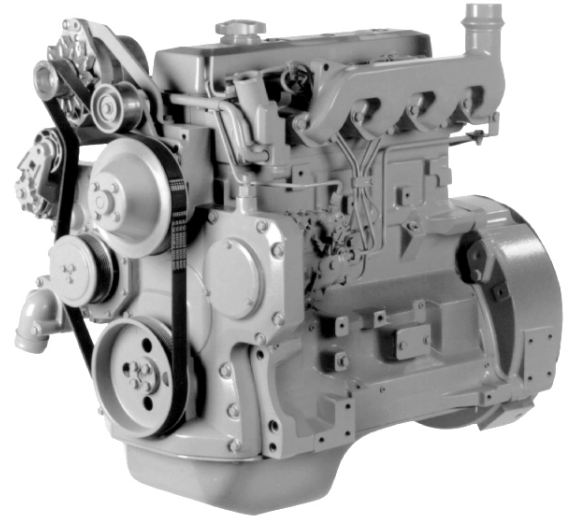

RATED BHP is the power rating for variable speed and load applications where full power is required intermittently.
CONTINUOUS BHP is the power rating for applications operating under a constant load and speed for long periods of time.
POWER OUTPUT is within + or - 5% at standard SAE J 1995 and ISO 3046.
TIER 2 EMISSION CERTIFICATIONS: CARB, EPA, and EU.

PERFORMANCE CURVE

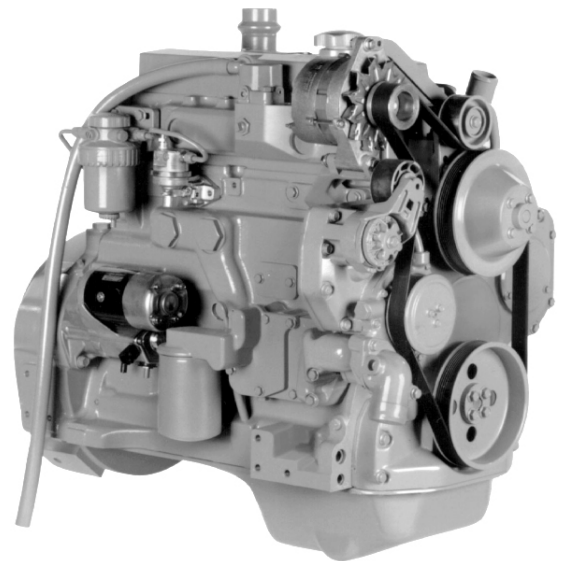
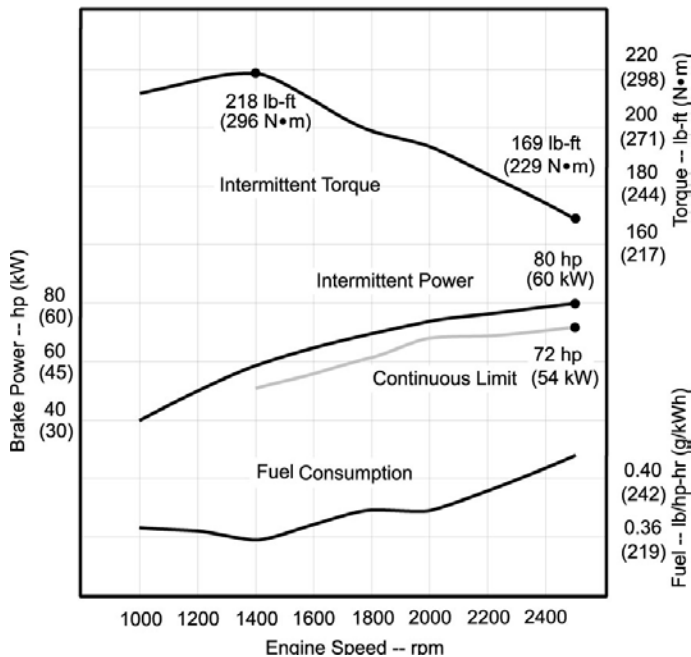

Photographs may show non-standard equipment



PowerTech™ 4045D Diesel Engine Specifications

GENERAL DATA

Model	4045DF270	Aspiration	Naturally Aspirated
Number of Cylinders	4	Length - in. (mm)	33.9 (860)
Displacement - L (cu.in)	4.5 (276)	Width - in. (mm)	24.1 (612)
Bore and Stroke - in. (mm)	4.19 x 5.00 (106 x 127)	Height - in. (mm)	33.3 (846)
Compression Ratio	17.6:1	Weight - lb (kg)	851 (387)
Engine Type	In-line, 4-Cycle		

DIMENSIONS

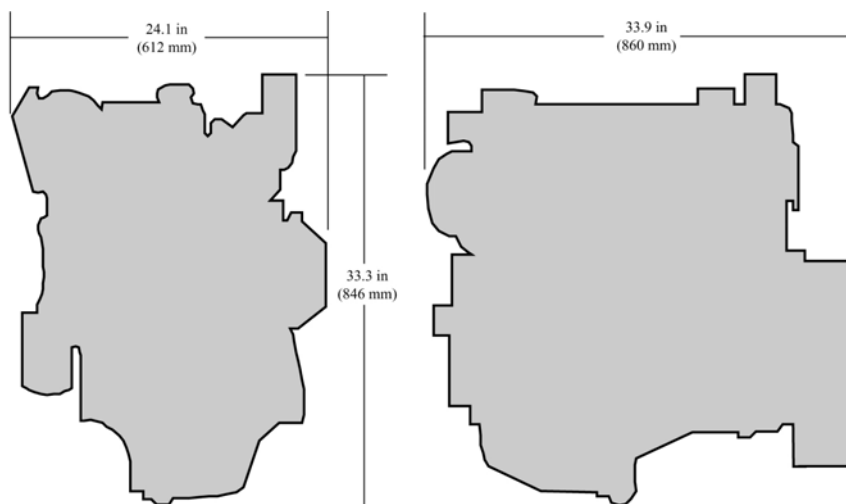

FEATURES AND BENEFITS

Dynamically Balanced Crankshaft

- Crankshafts are formed from nodular iron

Forged-Steel Connecting Rods

- Unique 45-degree design permits use of larger crankshaft connecting-rod bearings for increased durability

Self-adjusting Poly-vee Fan Drive

- Self-adjusting, eight-groove, poly-vee fan drive provides multiple fan drive ratios and fan heights that can be matched to specific application requirements
- Poly-vee design provides more than twice the drive capacity

Replaceable Wet-Type Cylinder Liners

- Provides excellent heat dissipation
- Precision machined for long life

Either-Side Service

- Engine installation and maintenance simplified and convenient by providing dipstick and oil filter options on both sides of the engine

500-Hour Oil Change

- Customers save significant costs on oil, filters and labor with a 500-hour oil change interval

Standard Gear Auxiliary Drive

- Standard gear auxiliary drive produces up to 50 hp (37 kW) for gear-driven accessories

Mounting Points

- Standard front and side mounting points provide easy installation and application flexibility

Electronic-Controlled Rotary Injection Pump

- Electronic-controlled rotary injection pump distributes the precise amount of fuel required by each cylinder at exactly the right time
- Electronic controls monitor engine speed and load to determine fuel timing

Optional Engine-Balancer Shafts

- Provides smooth engine operation

Specifications and design subject to change without notice



John Deere Power Systems
3801 W. Ridgeway Ave.
PO Box 5100
Waterloo, IA 50704-5100
Phone (800) 533-6446
Fax (319) 292-5075

John Deere Power Systems
Usine de Saran
La Foulonnerie - B.P. 11013
45401 Fleury-les-Aubrais Cedex-France
Phone (33) 2 38 82 61 19
Fax (33) 2 38 82 60 00