

21 1/2"

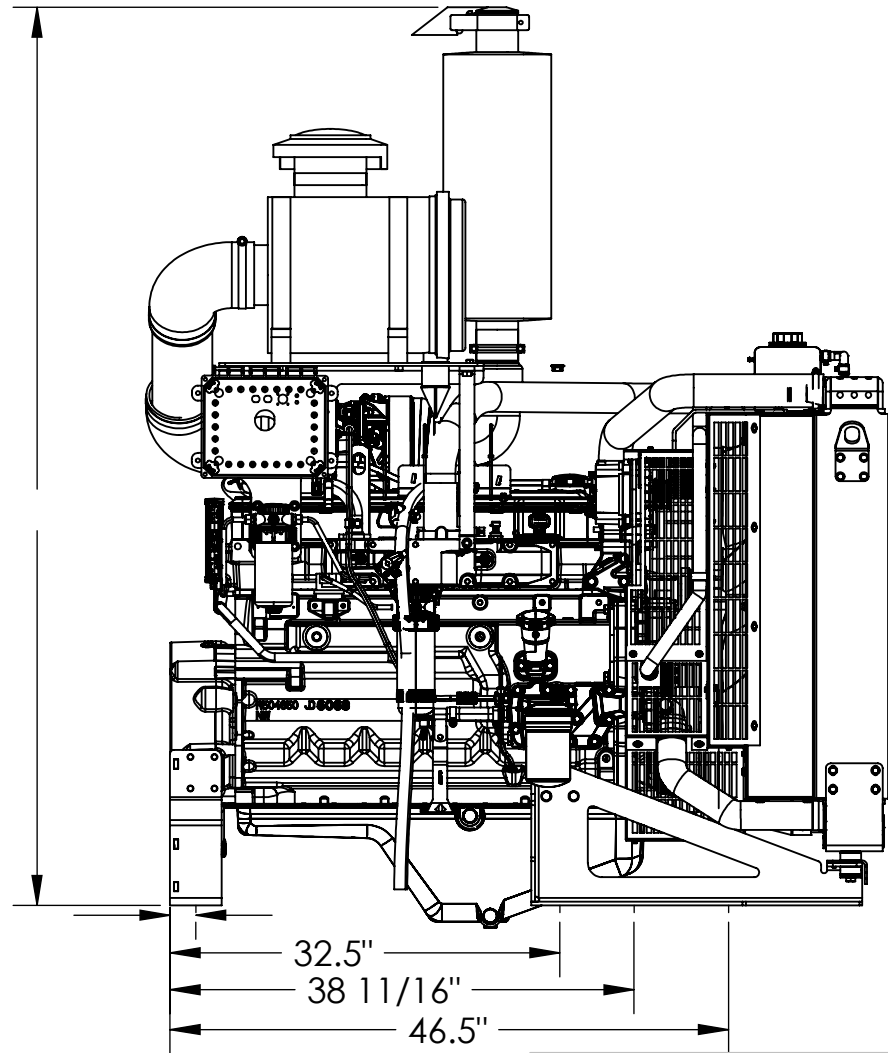

32.5"

38 11/16"

46.5"

**SAE NO. 3 FLYWHEEL HOUSING
 FLYWHEEL 11 1/2
 RH SERVICE, FILTERS, DIPSTICK & OIL FILLER
 EPA MEETS TIER 3 STANDARDS**

PROPRIETARY AND CONFIDENTIAL

THE INFORMATION CONTAINED IN THIS DRAWING IS THE SOLE PROPERTY OF FLINT POWER SYSTEMS. ANY REPRODUCTION IN PART OR AS A WHOLE WITHOUT THE WRITTEN PERMISSION OF FLINT POWER SYSTEMS IS PROHIBITED.



TITLE:

OPEN POWER UNIT
 6 CYLINDER, 6.8 LITERS
 4 VALVES PER CYLINDER

A

DWG. NO.
 OP6068HF485_275 HP

SCALE: 1:16 WEIGHT:

SHEET 1 OF 1